

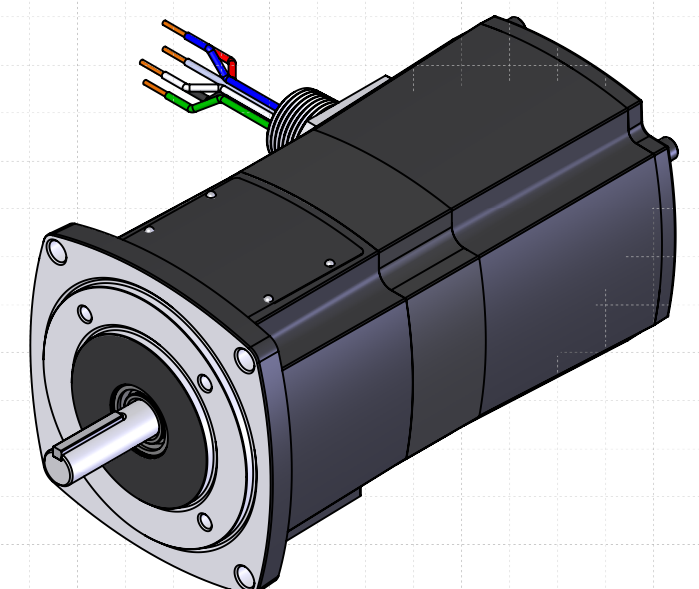

DESCRIPTION:
MOTOR 34R6BXPP

SHEET: 1/1
SCALE: 3:5
C
UNLESS OTHERWISE SPECIFIED:
UNITS ARE IN INCHES [mm]
TOLERANCES: .XX:±.01 .XXX:±.005
ANGLES: X°:±3° X.X°:±0.5°

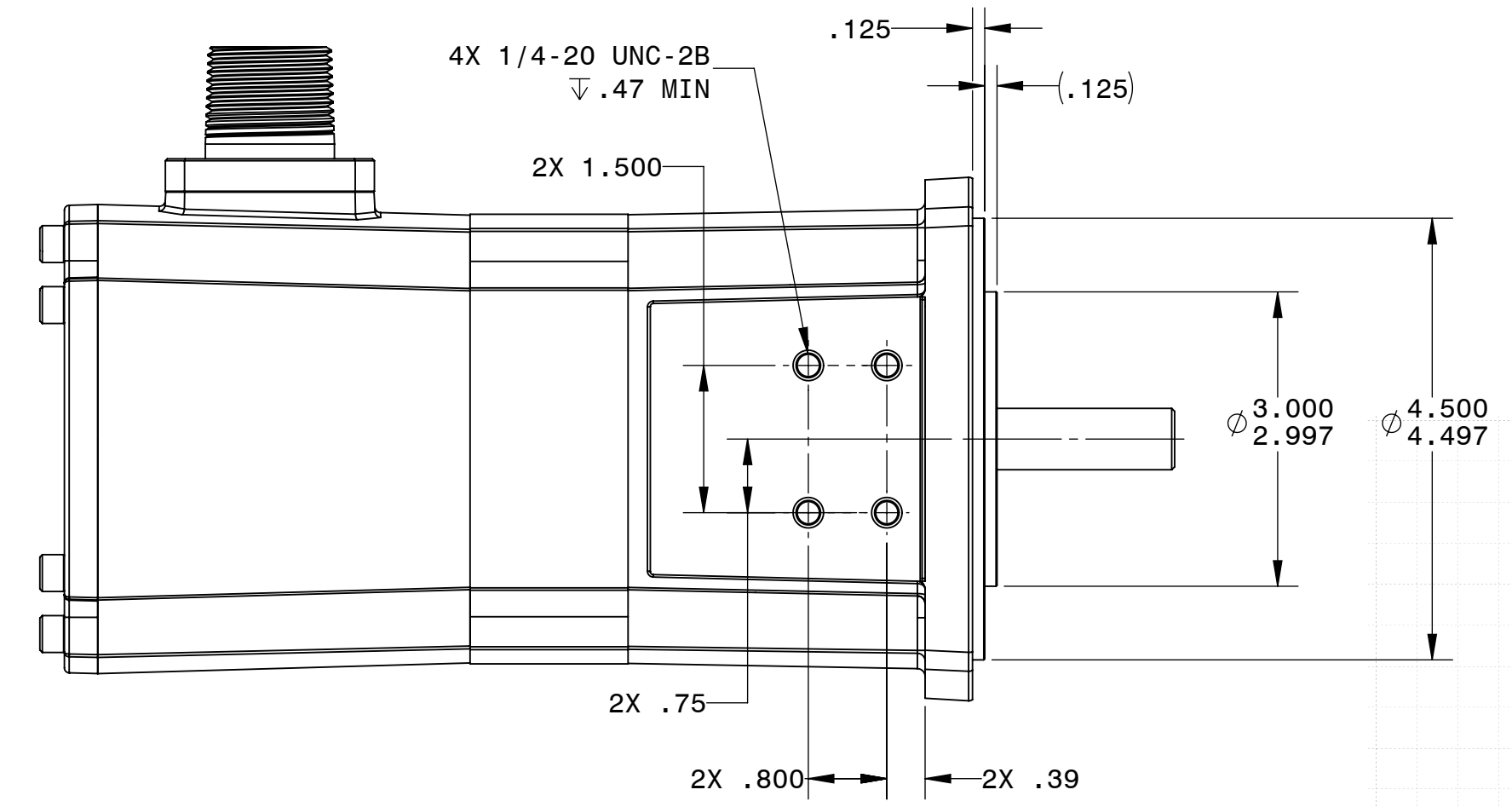
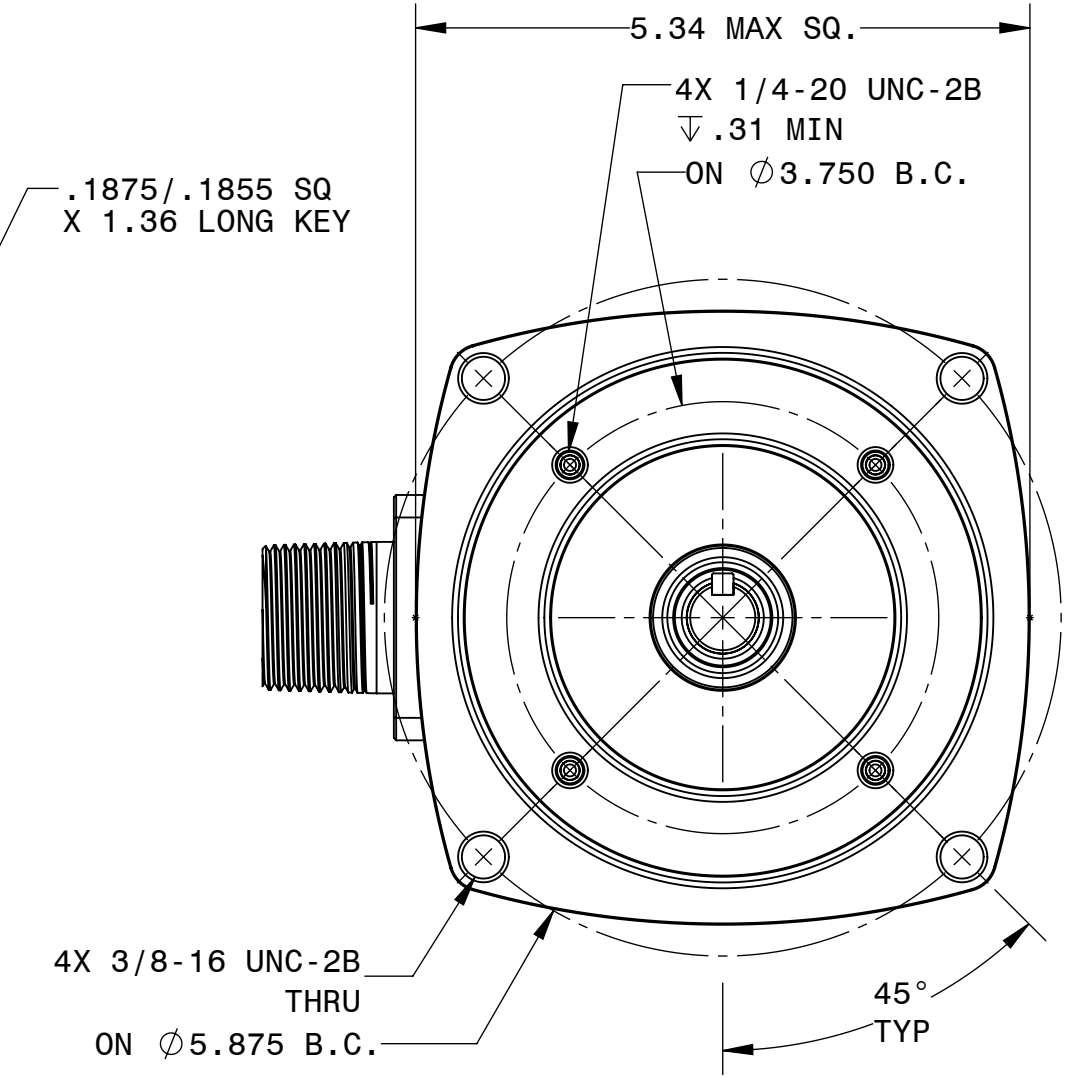
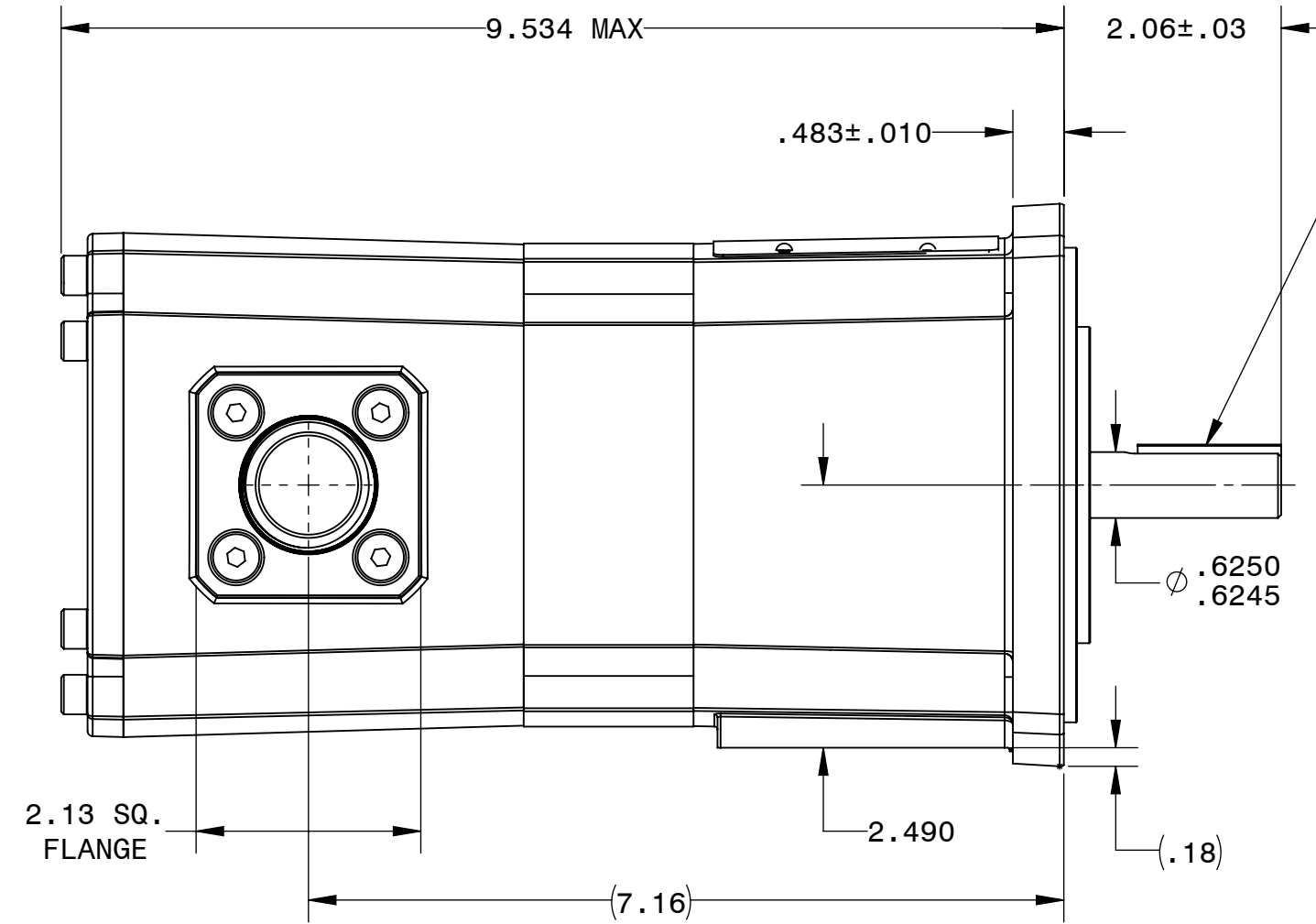
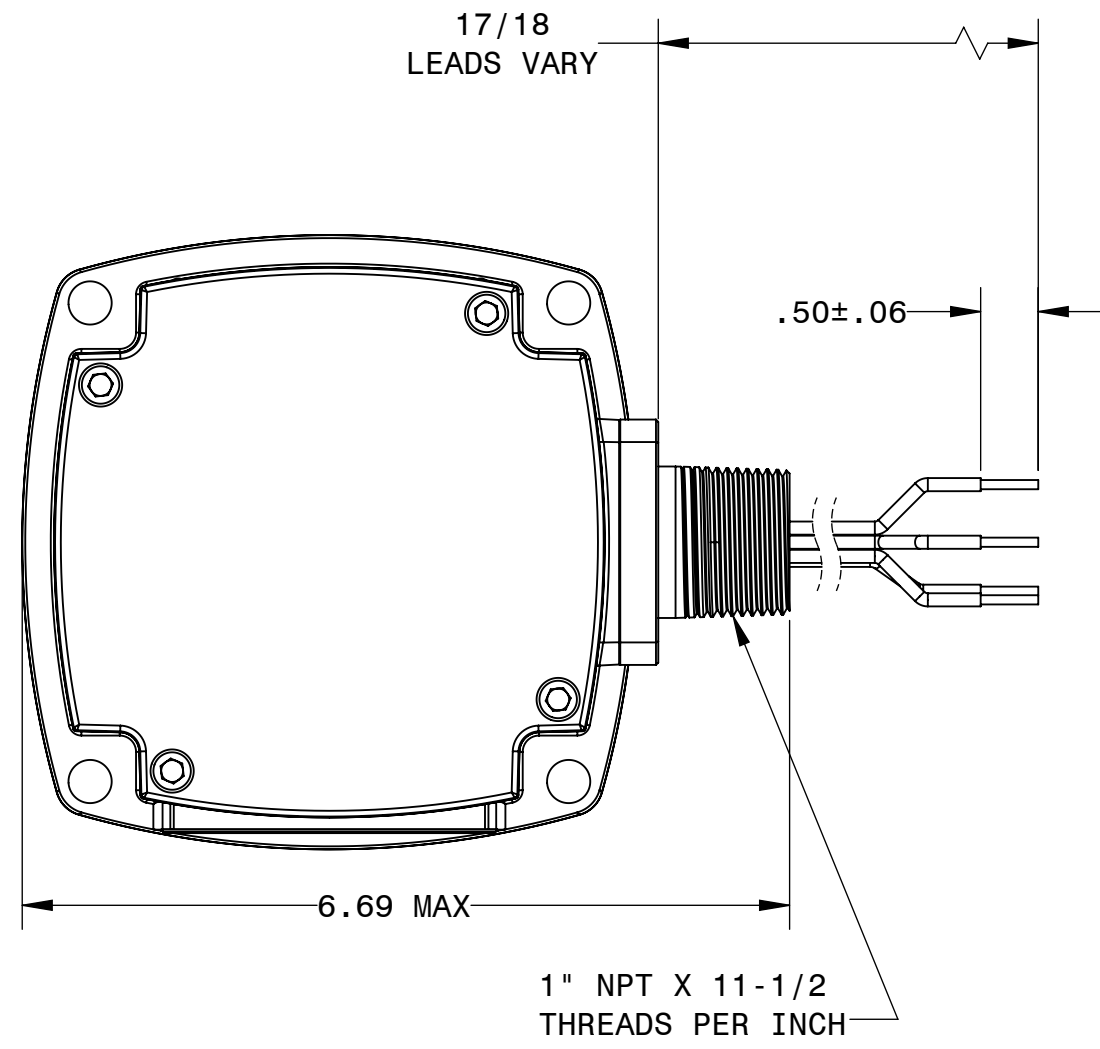

REPRESENTATIVE OF MODEL NUMBER(S):
3263 3264